



NANORACKS

First Commercial Laboratory in Space





**Component of NASA
U.S. National Lab**

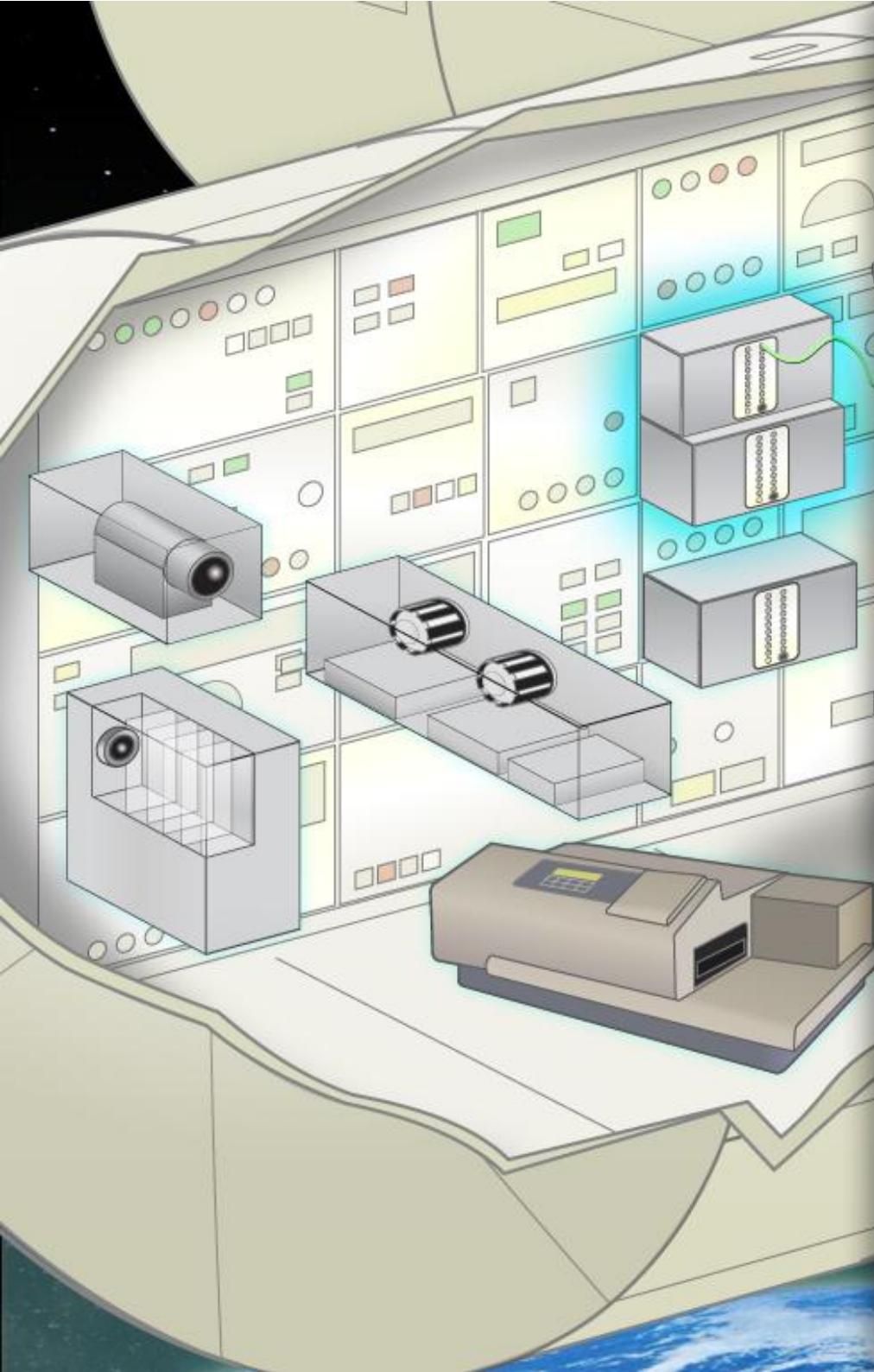

NanoRacks Platform-1 and NR-2

- Two research platforms installed on U.S. National Lab
- 16 payload slots in the CubeSat form factor of 10 cm by 10 cm by 10 cm
- USB standard interface
- 5 V DC 2W each slot
- Near real time data
- 30 day standard mission
- Crew time included
- Ambient temperature

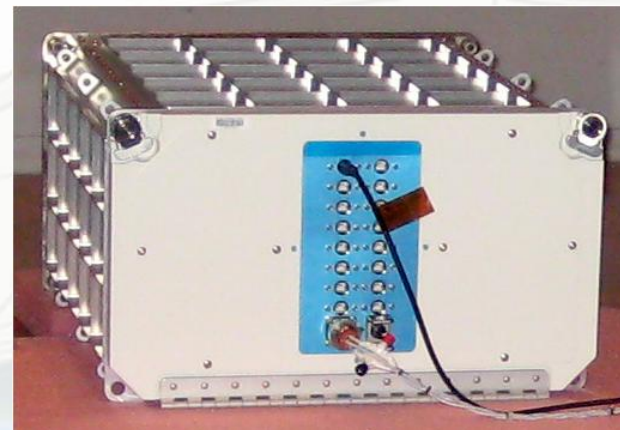

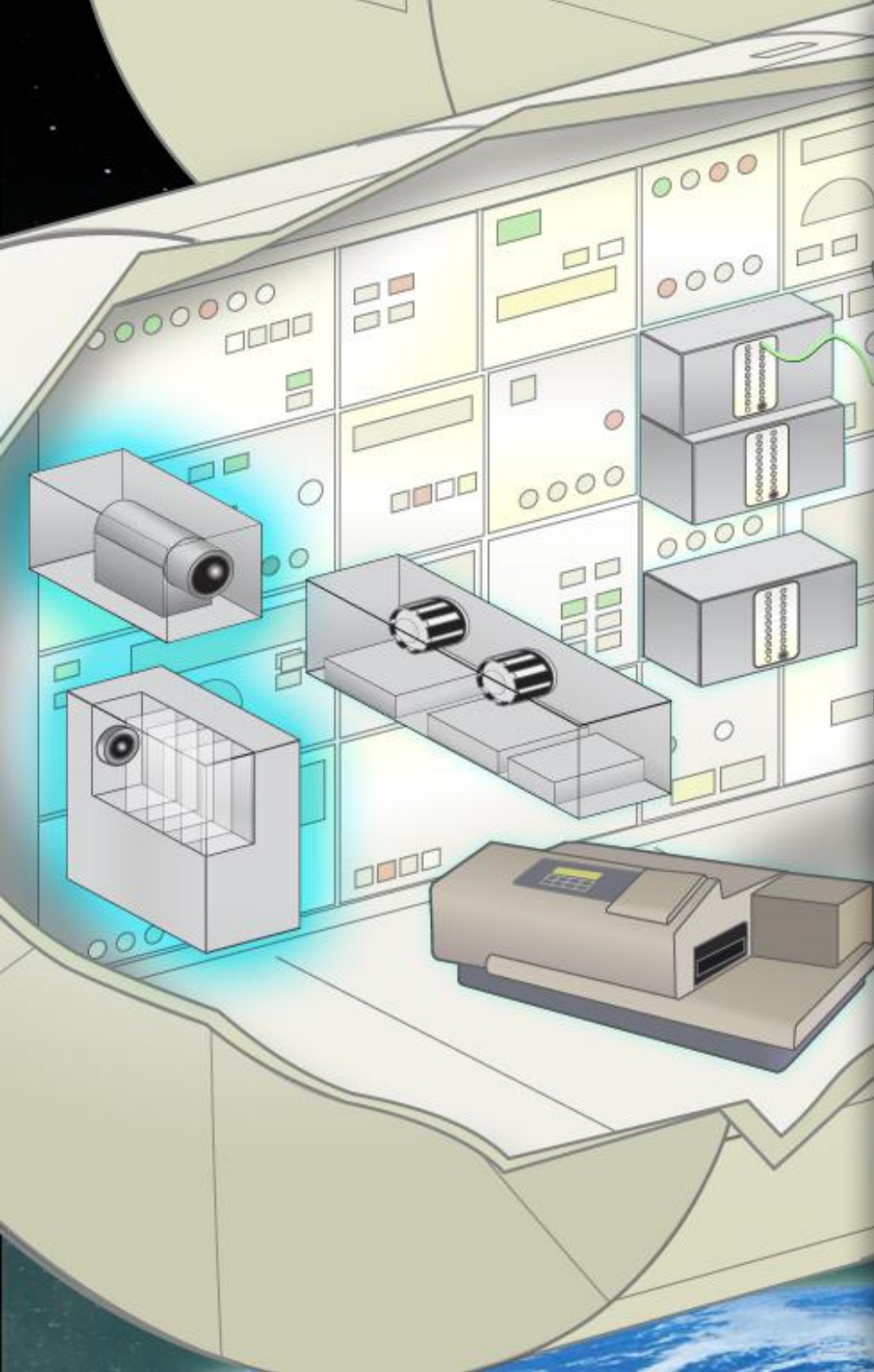

NanoRacks Microscope-1

- Optical Transmission Microscope
- USB Camera
- 5 minute set up
- USB standard interface
- Up to 1880X magnification
- Astronaut tended

NanoRacks Microscope-2

- Reactor
- Optimal for microgravity
- Does not require “glove box” operation
- Can be used in a glove box



- 1



- 2

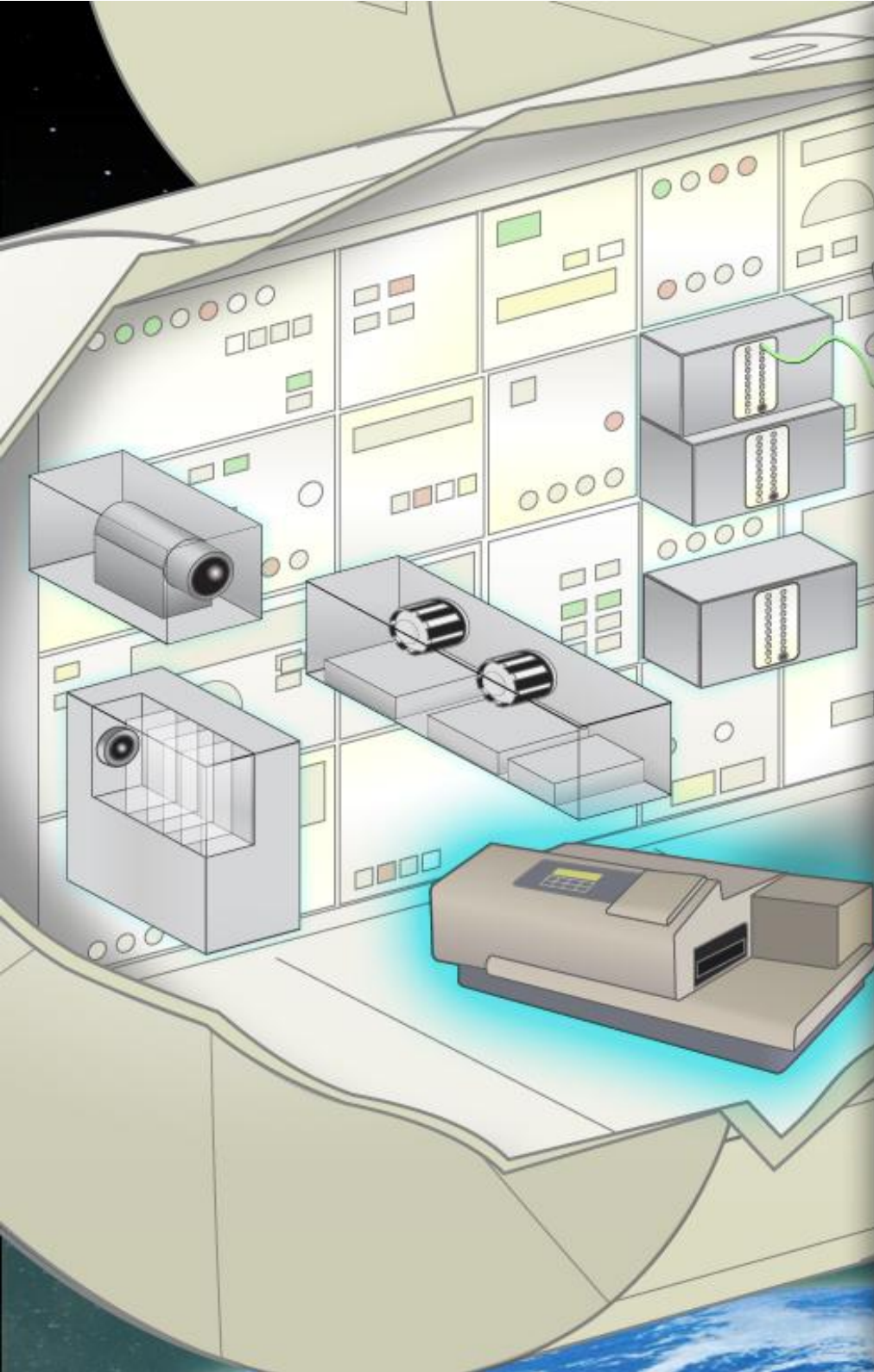

NanoRacks Plate Reader

- Off the shelf Molecular Devices M5E
- Uses the Nanoracks-Microgravity-Microplates that holds 96 wells
- Takes one minute analysis for 96 wells
- Temperature controlled (heated)
- Stirring function
- Side cuvette port
- Operational 2nd quarter of 2012

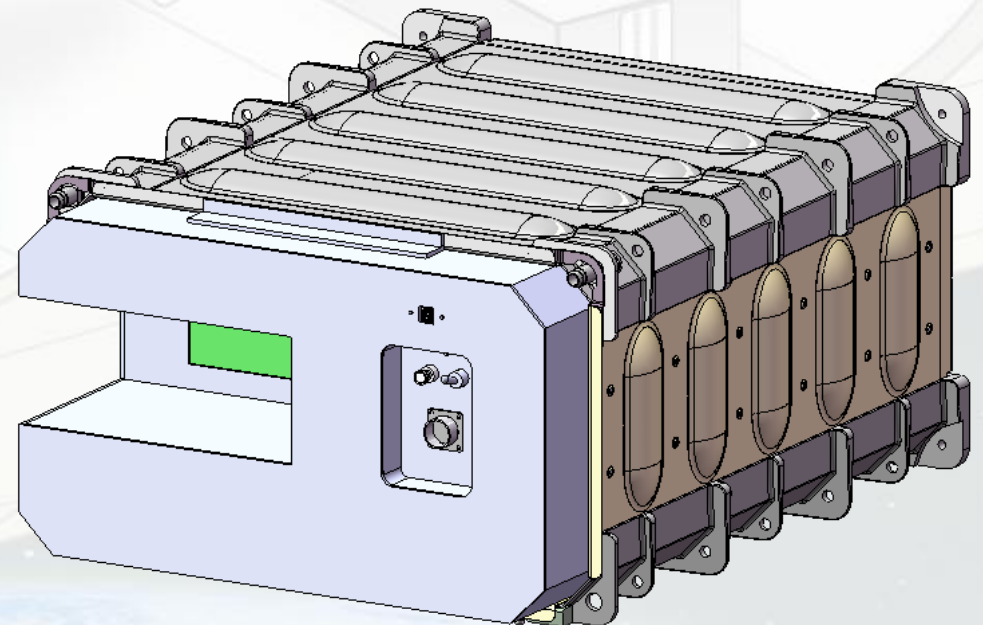

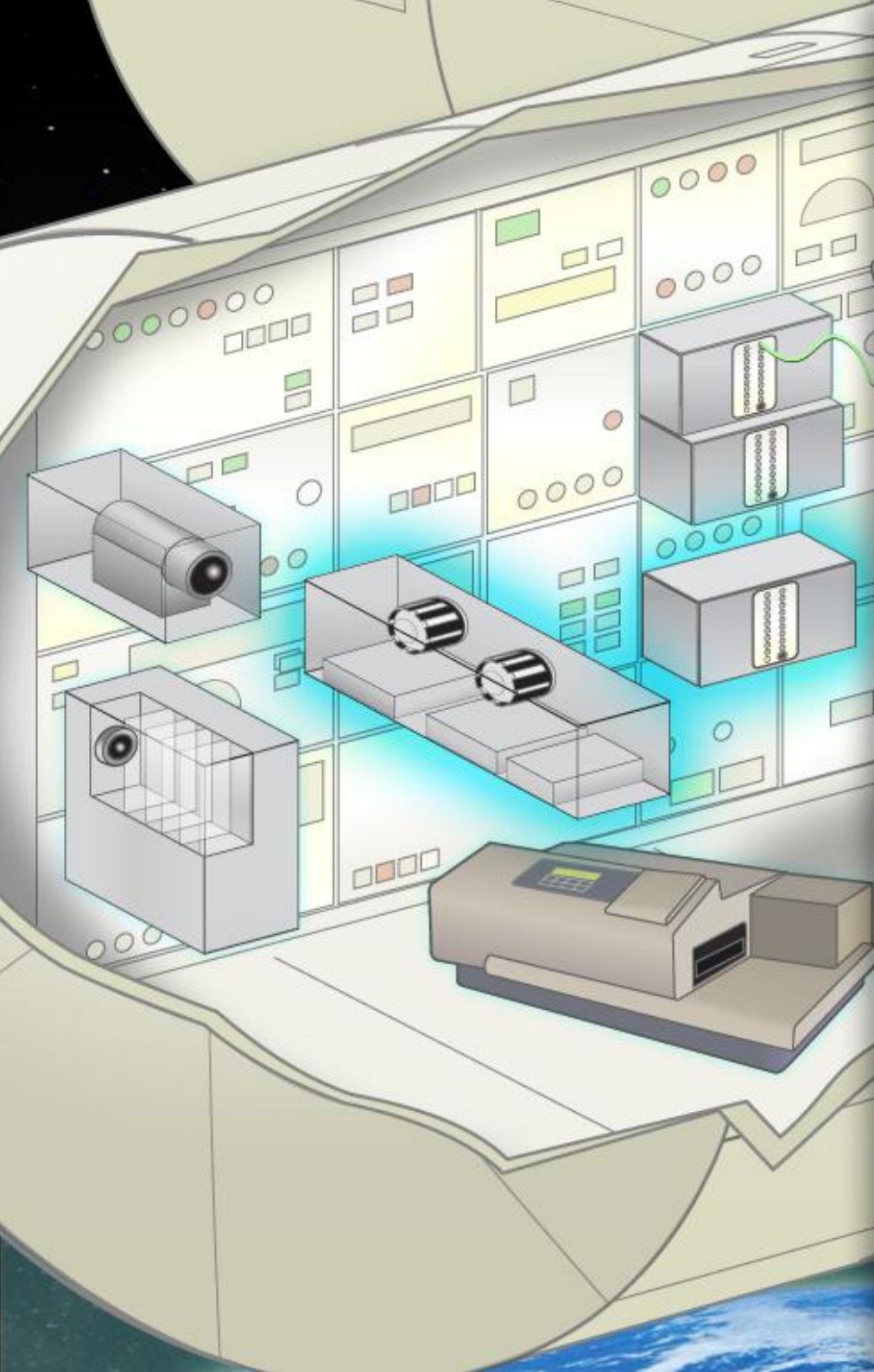

NR-3 Third Platform

- Partially NASA funded 3rd platform
- Will include NR-Astrium 4U Centrifuge
- In addition will support two 4U Super-Cubes
- 28V DC per slot 50 W per slot
- near real time data
- Available 2nd quarter 2012

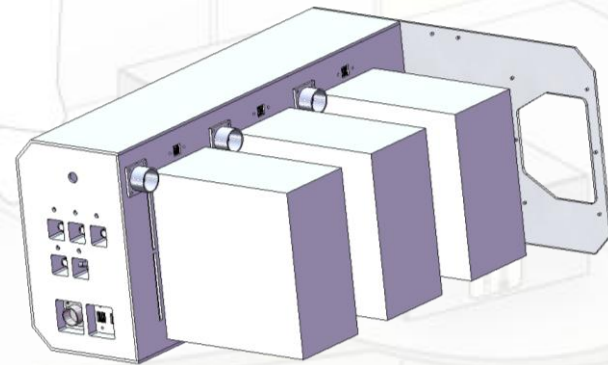

NR-4 NanoRacks External Platform

- Available 2013
- CubeSat form factor payloads external to station
- CubeSat Deployment

NanoLabs

- Educational Experiments
- Massively Parallel Experiment
- Students Operate Ground Control
- Crystal Growth
- Internet Interface
- Starts in January 2012



Fluid MixStix

- 7.7 mL Volume
- Lightstick Operation
- Fluid Mixing
- 24/2CU Box
- Flight Proven
- Returned on Soyuz

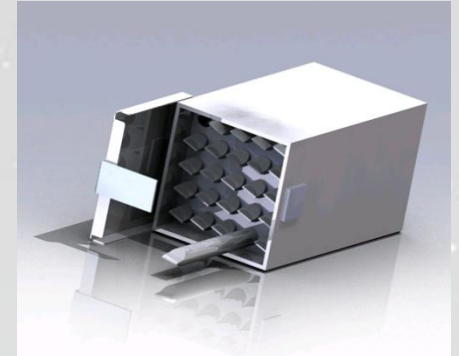

Secondary Payload Opportunities

- GEO Shared Ride
- Falcon 9 External
- Progress/Soyuz
- ATV/HTV

Other Opportunities

- Orbital Bookings
- Internet Based Experiments
- Rapid Prototyping
- DragonLab
- TRL Raising

Extra Services

- Design
- Safety
- Integration
- Verification
- Late Access/Early Retrieval
- Launch/Landing Facilities
- Operations Control Center

Frequently Asked Questions

Q - How do I get started?

A - Fill out our website questionnaire

Q - What can I fly?

- A** - Electronics are easy
- Triple contained for toxic items
 - No radioactive items
 - Stay in our box...

Q - How long does it take?

- A** - About 9 months
- 1 month on-orbit

Q - What Does Commercial Mean?

- A** - Contract with NR
- Information kept Proprietary
 - Fast track commercial practices
 - No need for NASA interface
 - All NASA regs handled by us
 - IP kept with you



www.nanoracks.com